

**BLDG A  
FLOOR PLAN**  
 SCALE 1/8"=1'-0"

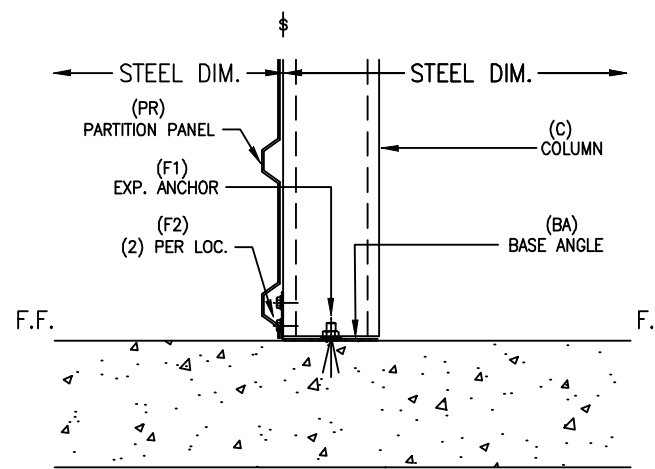

5 FLOOR BASE ANGLE AT PARTITION WALL

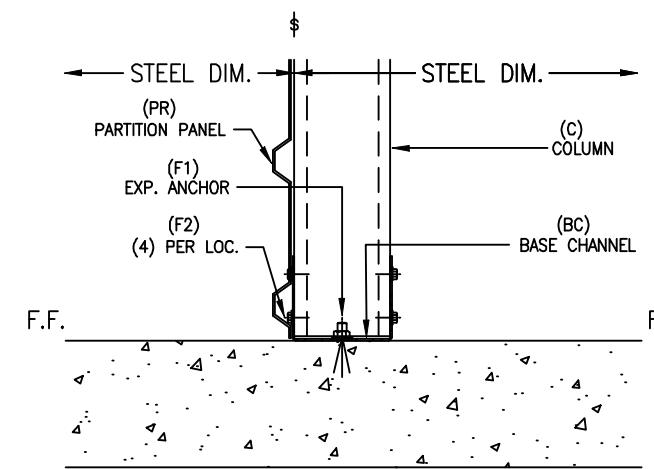
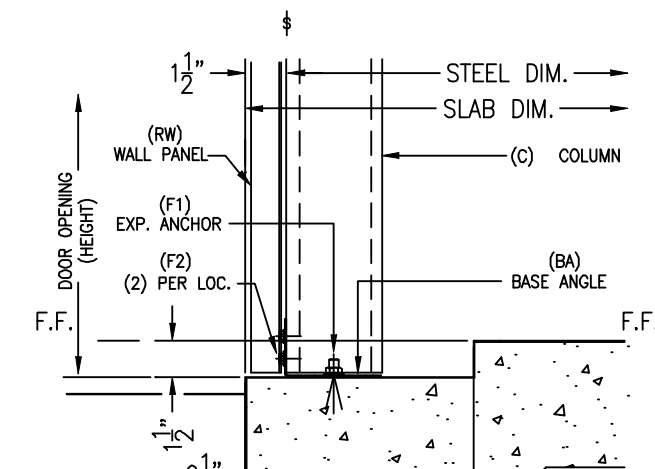

4 FLOOR BASE CHANNEL AT PARTITION WALL



3 SHEETED WALL EDGE BASE

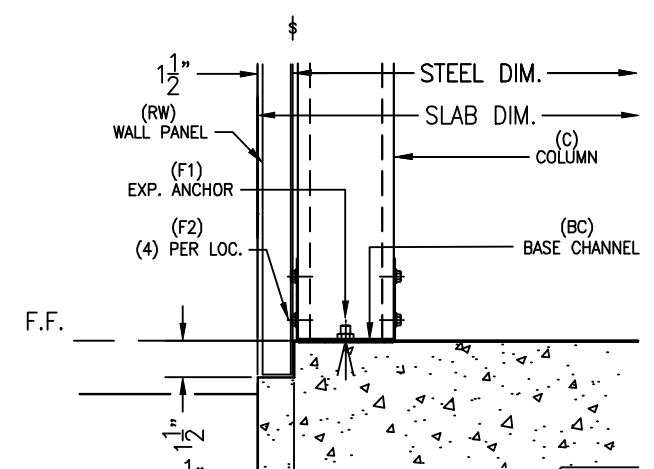

2 WALL EDGE BASE

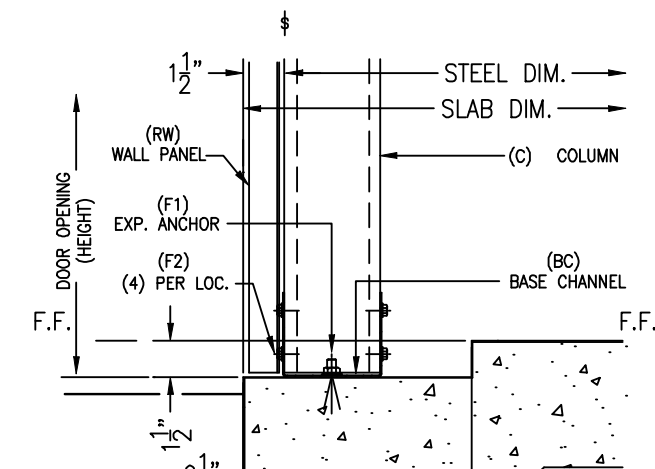

1 DOOR EDGE BASE

**STRUCTURAL SCHEDULE**

(BA) - B421BR 4 X 3 X 1/2 X 16GA ANGLE (8.9)	- FLOOR BASE ANGLE
(BC) - U4251BR 4 1/8 X 2 7/8 X 16GA CHANNEL (9.9)	- FLOOR BASE CHANNEL
(CL) - C421BR 4 X 2 X 16GA ZEE (8.9)	- 4" COLUMN
(CR) - C2251BR 6 X 2 1/2 X 16GA ZEE (11.9)	- 6" COLUMN
(C4) - C421BR 4 X 2 X 16GA ZEE (8.9)	- DOOR HEAD
(C5) - C4251BR 4 X 2 X 16GA ZEE (8.9)	- DOOR JAMB
(C6) - U4251BR 4 1/8 X 2 7/8 X 16GA CHANNEL (9.9)	- EAVE CHANNEL
(E) - E431BR/20.3 X 6 X 4 X 16GA STRUT (13.9)	- EAVE STRUT
(F) - AS MANUFACTURED	- FLOOR CLIP
(G) - C421BR 4 X 2 X 16GA ZEE (8.9)	- GIRT
(H) - B421BR 4 X 2 X 16GA ANGLE (8.9)	- HALL TOP ANGLE
(I) - C421BR 4 X 2 X 16GA ZEE (8.9)	- DOOR HEAD REINFORCEMENT
(J) - C2251BR 6 X 2 1/2 X 16GA ZEE (11.9)	- JACK RAFTER
(K) - C1241BR 12 X 4 X 16GA ZEE (20.9)	- MILLION
(L) - B421BR 4 X 2 X 16GA ANGLE (8.9)	- MIN CLIP
(M) - C4251BR 2 1/2 X 8 X 2 1/2 X 16GA ZEE (9.9)	- ROOF PURLIN
(N) - Z6251BR 2 1/2 X 8 X 2 1/2 X 16GA ZEE (11.9)	- ROOF PURLIN
(O) - Z6251BR 2 1/2 X 8 X 2 1/2 X 16GA ZEE (13.9)	- ROOF PURLIN
(P) - B421BR 4 X 2 X 16GA ANGLE (8.9)	- PARTITION ANGLE
(R) - B421BR 4 X 2 X 16GA ANGLE (8.9)	- RAKE ANGLE
(S) - E431BR/20.3 X 6 X 4 X 16GA STRUT (13.9)	- ROSE STRUT

**SHEETING SCHEDULE**

(ML) - Z6GA M-LOC WALL PANEL	- FLOOR BASE ANGLE
(PL) - Z6GA PANEL-LOC WALL PANEL	- FLOOR BASE CHANNEL
(RL) - Z6GA R-PANEL WALL PANEL	- 4" COLUMN
(RR) - Z6GA PBR ROOF PANEL	- 6" COLUMN
(RW) - Z6GA PBR WALL PANEL	- DOOR HEAD

**FASTENER SCHEDULE**

(F1) - CONC. EXP. ANCHOR (SIZE BY CUSTOMER)	- BASE TO SLAB CONNECTIONS
(F2) - 12 X 1 SD TEK (PLT)	- STRUCTURAL STEEL CONNECTIONS
(F3) - 12 X 1 SD TEK (PLT)	- PARTITION SHEETING
(F4) - 12 X 2 SD TEK (PLT)	- PARTITION ANGLE CONNECTIONS
(F5) - 12 X 1 1/4 WASHER TEK(OR ZAK)(PTD)	- EXTERIOR WALL SHEETING
(F6) - 12 X 1 1/4 WASHER TEK(OR ZAK)(PTD)(PLTD)	- ROOF SHEETING
(F7) - 12 X 1 1/4 WASHER TEK(OR ZAK)(PTD)	- EXTERIOR TRIM DRILLER
(F8) - 14 X 7/8 WASHER TEK(OR ZAK)(PTD)	- EXTERIOR WALL PANEL LAP
(F9) - 14 X 7/8 WASHER TEK(OR ZAK)(PTD)(PLTD)	- ROOF PANEL LAP
(F10) - 14 X 7/8 WASHER TEK(OR ZAK)(PTD)	- EXTERIOR TRIM LAP
(F11) - 1/8 POP RIVET	- EXTERIOR TRIM
(F12) - 12 X 1 1/4 WASHER TEK(OR ZAK)(PTD)	- INTERIOR WALL SHEETING
(F13) - 12 X 1 1/4 WASHER TEK(OR ZAK)(PTD)	- INTERIOR TRIM DRILLER
(F14) - 14 X 7/8 WASHER TEK(OR ZAK)(PTD)	- INTERIOR WALL PANEL LAP
(F15) - 14 X 7/8 WASHER TEK(OR ZAK)(PTD)(PLTD)	- INTERIOR TRIM LAP
(F16) - 1/8 POP RIVET	- INTERIOR TRIM

**TRIM SCHEDULE**

(BTR) - 1" ROLL MASTIC	- R PANEL INSIDE FOAM CLOSURE
(CLN) - R PANEL INSIDE FOAM CLOSURE	- R PANEL INSIDE CORNER TRIM
(CLOUT) - R PANEL INSIDE FOAM CLOSURE	- DOOR CORNER MULLION
(G) - GUTTER SEAL	- DOWNSPOUT WITH KICK OUT
(IC) - R PANEL INSIDE CORNER TRIM	- DOWNSPOUT STRAP
(ICN) - R PANEL INSIDE CORNER TRIM	- EAVE FLASHING
(ICW) - R PANEL INSIDE CORNER TRIM	- FORMED RIDGE CAP
(ID) - DOOR CORNER MULLION	- GUTTER END CAP
(IDK) - DOOR CORNER MULLION	- GUTTER HANGER STRAP
(IDW) - DOOR CORNER MULLION	- POST HUNG GUTTER
(IDY) - DOOR CORNER MULLION	- DOOR HEAD COVER
(IDZ) - DOOR CORNER MULLION	- DOOR HEAD TRIM
(IDY) - DOOR CORNER MULLION	- HIGH EAVE TRIM

**TRIM SCHEDULE**

(ICB) - INSIDE CORNER BOX	- INSIDE CORNER BOX
(ICN) - INSIDE CORNER BOX	- LOW RIS INSIDE CORNER TRIM
(ICW) - INSIDE CORNER BOX	- DOOR JAMB TRIM
(ICX) - INSIDE CORNER BOX	- DOOR JAMB CAP
(ICZ) - INSIDE CORNER BOX	- LOW RIS HEAD AND JAMB TRIM
(IDC) - INSIDE CORNER BOX	- DOOR MULLION COVER TRIM
(IDN) - INSIDE CORNER BOX	- LOW RIS OUTSIDE CORNER TRIM
(IDW) - INSIDE CORNER BOX	- OUTSIDE CORNER BOX
(IDY) - INSIDE CORNER BOX	- PEAK BOX
(IDZ) - INSIDE CORNER BOX	- RAKE TRIM END CAP
(IDY) - INSIDE CORNER BOX	- RAKE TRIM
(IDZ) - INSIDE CORNER BOX	- HALL TOP TRIM
(IDY) - INSIDE CORNER BOX	- ROOF TIE IN TRIM
(IDZ) - INSIDE CORNER BOX	- ROOF STEP TRANSITION FLASHING
(IDY) - INSIDE CORNER BOX	- 4OZ. TOUCH UP SPRAY PAINT

  
 self-storage systems  
 By Central States Manufacturing  
 302 Jane Place, Lowell, AR 72745  
 (877)770-5206 fax (800)356-2971  
 www.centralstatesmfg.com

**project-** NEW STORAGE BUILDING PROJECT FOR:  
 NOT FOR CONSTRUCTION  
  
**customer-** PRECONSTRUCTION REVIEW DRAWINGS

**draft-ink**  
 p.o. box 14888 springdale, mo. 65814-0888  
 417.887.0101 fax.888.9064  

drawn	date	chkd	date
TVP	01.01.04		

  
**sheet of**  
**D02-06**